ABSTRACT

A sensor node hold small amount of resources in terms of processor, battery power, memory and communication range, but when a huge number of sensor nodes work together they are able to complete a good volume of task. It is just because of Wireless Sensor Network we are able to cooperate with physical world directly. In this context, hierarchical routing protocols offer energy-efficiency, scalability and reliability for WSN applications. With this goal in mind, this paper proposes to approve a Cluster-based approach for Energy-efficiency in the WSN (REER)protocol. The main purpose of REER is to provide energy-efficiency by using for cluster formation and a probability function for Cluster Head election. Simulations were conducted to show the benefits of REER compared with LEACH.

KEYWORDS: LEACH Protocol, DD Leach ,S Leach, REER

INTRODUCTION

Wireless Sensor Networks (WSNs) [1] are networks of light-weight sensors that are battery powered consumed majorly for monitoring purposes. WSNs are growing equipped to handle some of these complex functions, in-network dispensation such as data aggregation, information fusion, computation and transmission activities requires these sensors to consume their energy efficiently in order to extend their effective network life time. Sensor nodes are ready to energy drainage and failure, and their battery source might be irreplaceable, instead new sensors are deployed. Thus, the stable re-energizing of wireless sensor network as old sensor nodes die out and/or the uneven terrain of the scope being sensed can lead to energy imbalances or heterogeneity among the sensor nodes. This can negatively impact the stability and execution of the network system if the extra energy is not properly utilized and leveraged. Various clustering schemes and algorithm such as LEACH, DEEC, have been proposed with varying objectives such as load equilibrate, fault- tolerance, increased connectivity with reduced delay and network longevity.

In recent years wireless sensor networks (WSNs) [2] has gained much attention due to the increase demand in the field of medicine, battle fields, identification of contaminated environments, environmental monitoring, analysis of structural conditions of buildings, roads and highways etc. These networks are distributed embedded system consisting of large collection of short range sensor nodes collectively work together to monitor a system or an environment. These nodes will sense, and gather information from the environment or system and transmit the data to Base Station. The nodes consist of the sensor module which senses the environment, the processor and memory which perform local computation on the sensed data and store data, the transceiver responsible for exchange information with neighbour nodes and a power supply unit for node's energy. This node architecture is shown in Figure 1.

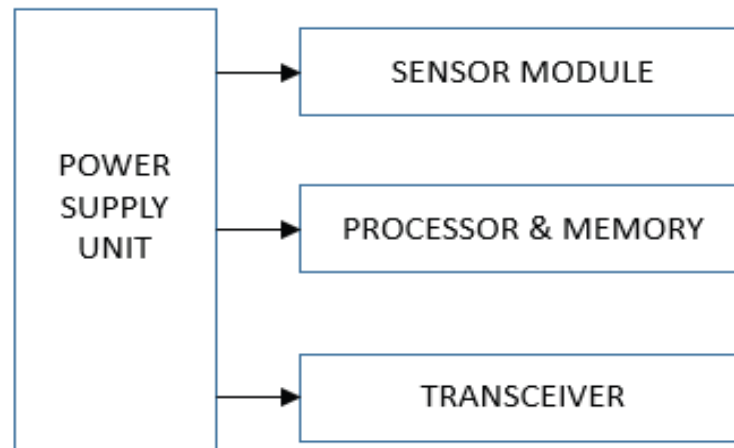

Figure 1: Node architecture

EXISTING TECHNIQUES OF LEACH PROTOCOL

To overcome limitations of the LEACH [3], some improvements have been incorporated into the LEACH protocol. Few improved routing protocols are: TL-LEACH, M-LEACH and DD-LEACH. These are hierarchical and more advanced over LEACH protocol, dissipate less energy as compared to LEACH and provide prolonged lifetime. All these improved protocols use clustering. Clustering has an advantage over other algorithms due to following reasons: minimization of energy consumption of intra-cluster as well as inter-cluster network, scalability of the network, prolonged network life time, reduction in information packet delay, and handling heterogeneity in the network.

DD-LEACH protocol

It is a combination of LEACH [3], a hierarchical based protocol and directed diffusion, a data-centric dissemination protocol. It supports two levels. At the first level, LEACH model is used and at the second level, directed diffusion model adopted. As in LEACH protocol, cluster formation is done, CH is particular over a cluster and TDMA schedule is distributed among nodes by CH. After undergoing setup and steady state phases, the BS transmits the query to the nearby CHs and those CHs in turn pass the query to other CHs. Hence the interest is communicated between all the CHs. The CHs act on the bases of the query received and forward the data to the BS. The CH forms a ramp with a nearby CH in order to communicate to the BS. The CH does not send data directly to the BS but through the protected path. The CH forwards only the aggregated query related data. Hence, considerable energy is well-maintained, and also due to the fact that the CHs are not communicating to the BS directly.

LEACH-C Protocol

LEACH-C [4] is also a cluster based protocol that uses a centralized clustering algorithm. The clusters are formed by the BS. Each node sends information about its current location and energy level to the BS. The BS computes the regular node energy, and whichever nodes have energy below this average cannot be cluster-heads for the current round. Using the residual nodes as possible cluster-heads, the BS finds clusters using the simulated hardening algorithm to solve the NP-hard problem of finding k optimal clusters. This algorithm attempts to minimize the amount of energy for the non-cluster head nodes to communicate their data to the cluster head, by minimizing the total sum of square distances between all the non-cluster head nodes and the closest cluster-head. Eventually, the BS broadcasts a message that covers the cluster-head ID for each node. The steady-state phase of LEACH-C is identical to that of LEACH. The problem with LEACH and LEACH-C is that it assumes that cluster-heads are uniformly distributed. The main concept behind this protocol is that by using a centralized control algorithm better clusters can be formed by dispersing the cluster heads on the basis of their geographical position throughout the WSN. That is the basic concept for LEACH-centralized (LEACH-C) as shown in Figure 2. All nodes send information about their location (using a GPS receiver) and their amount of energy left to the BS, during LEACH-C's setup phase. In addition to making ideal clusters for the WSN, the BS needs to make sure that all nodes distribute energy evenly among themselves.

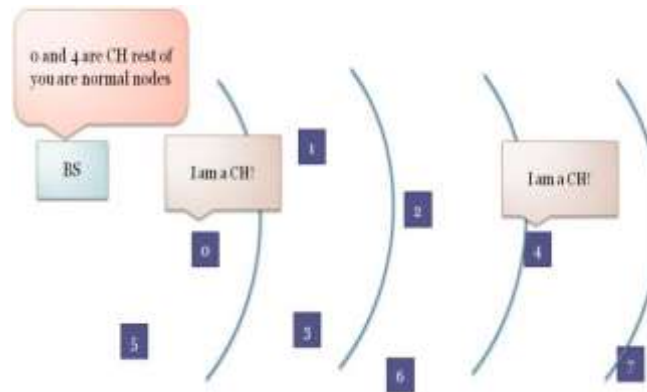

Figure 2: LEACH-C Architecture

SLEACH

This is the first [5] modified secure version of LEACH called SLEACH, which investigated the problem of adding protection to cluster-based communication protocol for homogeneous wireless sensor networks involving of sensor nodes with strongly limited resources. SLEACH provides protection in LEACH by using the structure block of SPINS (Security Protocol for Sensor Network), symmetric-key methods and MAC (Message Authentication Code). SLEACH protects beside selective forwarding, sinkhole and HELLO flooding attacks. It prevents intruder to send factitious sensor data to the CH and CH to forward phony message. But SLEACH Cannot prevent to crowd the time slot agenda of a cluster, causing DoS attack or merely lowering the throughput of the CH and does not assurance data confidentiality. The solution is meant to protect only outsider attack.

RLEACH

Secure solution [5] for LEACH has been introduced called RLEACH in which cluster are formed dynamically and periodically. In RLEACH the orphan node problem is higher due to random pair-wise key scheme so they have applied improved random pair-wise key scheme to stuned. RLEACH has been used the one way hash chain, symmetric and asymmetric cryptography to endow protection in the LEACH Hierarchical routing protocol. RLEACH protest many attack like spoofed, alter and replayed information, sinkhole, worm- hole, selective furthering, HELLO flooding and Sybil attack.

PURPOSED ALGORITHM

REER algorithm details

The operation of REER is broken upon in to some steps, where initial step is cluster building stage, after building of clusters second step is election of cluster head based on cost value calculations which is calculated by some random node chosen as supervisor node outside the cluster followed by third step which is data transmission phase in which data is transmitted from that supervisor node to the base station and alteration of cluster is done based on packet loss ratio calculated by supervisor node itself. In order to minimize overhead, the data transmission and cluster size alteration phase is long compared to the cluster building phase.

Factors for expense value

The expense value (EV) is determined based on following factors:

Residual energy (E)

The residual energy of a node preferably is greater than the approximate energy dissipated in previous round by the cluster head.

Distance to coordinator node (D)

We know that energy consumption is directly proportional to the square of distance. The nodes which are having the less distance from supervisor node should have greater probability to become cluster head of cluster.

Expense value depends upon what is the residual energy of a node how much distance from the supervisor node. The cost is greater when the residual energy is more and the less distance to the supervisor node.

Formula for EV is given by

$$EV = (a \times E) + (b \times (1/D)) \dots\dots\dots (1)$$

Where a and b are taken as normalization constants.

And E and d is defined as residual energy and distance to coordinator node respectively

Data loss ratio calculation

We are considering the forward node count for each node which defines the broadcast and rebroadcast probability of a node. Forward node count is denoted by FNC.

Initially $FNC [N_k] = FNC_{min}$, for all the nodes $N_k, k=1,2,\dots$

FNC_{min} is defined as the minimum number of forwarding nodes. Without any loss of packet in general case we can consider that

$FNC_{min} = 1$, steps involved in Adaptive energy efficient forwarding phase are described below:

- If N wants to forward the data collected to the BS, it adds its cost to the data packet and then broadcast the data packet to the closest neighbors.
- When neighbor N_1 gets the packet from N . it first determines whether its cost is low than that of N . in case of less cost, it further send out or forward the packet. Otherwise if N_1 is not in the direction of BS, it drops the packet.
- Destination D calculates the loss ratio (LR) when packets reach to it. Loss ratio is defined as ratio of total packets broadcast and total packets dropped from the source.
- D gives back this value of LR as a feedback to the Source node N .

After receiving LR by source node N , it analyzes this value of LR. It then changes the value of FNC as

$$FNC = FNC + \alpha, \text{ if } LR > LR_{max} \dots \dots \dots (b)$$

Where we are taking α as min. decrement of the increment count and LR_{max} is defined as the max threshold value of LR.

Then after modifying FNC it rebroadcast the data packets.

When the rebroadcast packets receives by the destination D , it again find out the LR and gives back to N . It then reassigns the value of FNC.

For $LR < LR_{max}$, then

$$FNC = FNC - \alpha, \text{ until } FNC \geq FNC_{min} \dots \dots \dots (c)$$

This method of data aggregation is efficient in terms of reliability and energy since,

- As loss ratio is measured by the SN itself delay is decreased. Because when we measure the LR at the BS it creates high delay.
- As we are modifying the size of the cluster energy dissipation is lowered. And it provides reliability also.

Data loss ratio calculation in our network

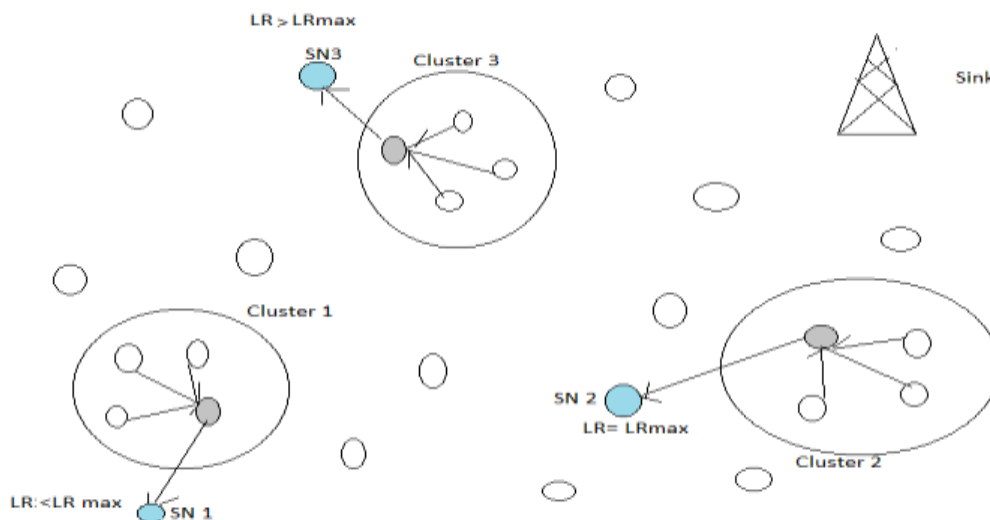

Figure 3 loss ratio calculation for clusters

Figure 3 shows that we are considering the case of three clusters with their corresponding supervisor nodes SN 1, SN 2, SN 3. Clusters DLR is measured by SNs itself. DLR is measured in terms of how many packets have been transmitted by CN to BS and how many packets have been received back by CN.

1 Rate vs delay graph for proposed protocol

In the figure 4 average end-to-end delay of our new proposed protocol is presented which is proven less than the existing LEACH protocol. We are comparing rate and delay ratio in terms of packet delivery. Congestion occurs when the sending rate will be increased from 100 to 250kb because it will result in increased traffic. Due to congestion there will be an increased amount of packet drops which will lead to increase in delay. But our proposed protocol delay is comparatively less because we are using cluster based approach having a supervisor node around the cluster which will lower the delay of data transmission from the sensor nodes to sink. The end-to-end-delay of network is averaged over total number of surviving data packets from the sources to the destinations. Surviving data packets are those data packets which are received by sink with no failure. Graph for average end to end delay is shown in figure 3

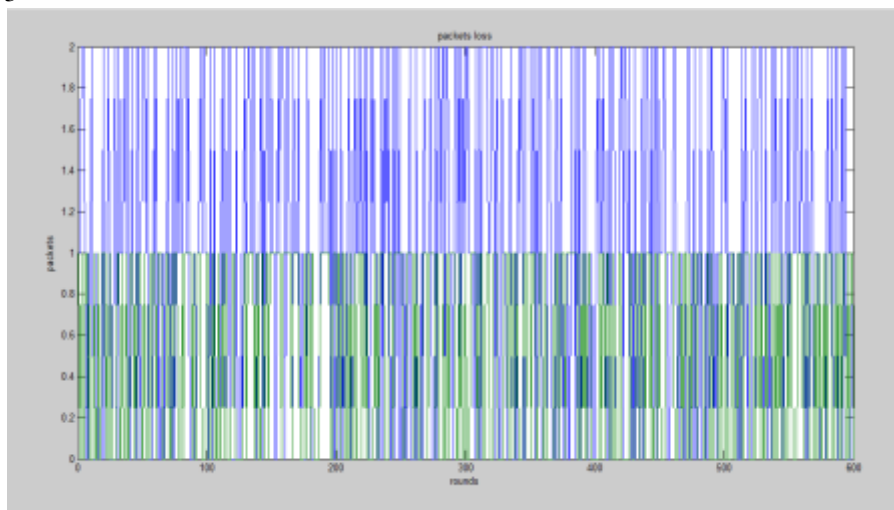

Figure 4 Delay according to rate

In figure 5, it can be evaluated that the packet delivery Ratio of our new proposed protocol is greater than the existing LEACH protocol. It is presented that with the increased rate there is increase in packet drop which will lead to reduction in delivery of packet. EERDAT is beneficial here when compared to LEACH because the new protocol calculates the data fatal ratio at the supervisor node and accordingly adjusts the cluster size based upon modification in their respective size

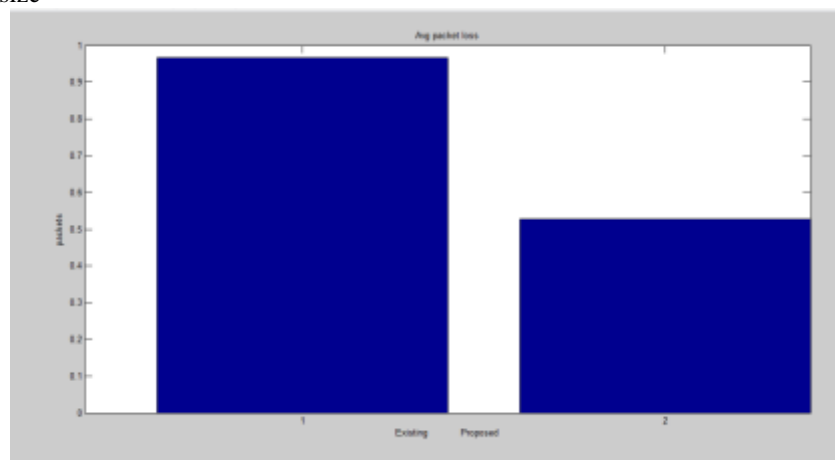

Figure 5 performance evaluation in terms of rate vs packet delivery ratio

CONCLUSION

Major issues like delay in terms of packet delivery, reliability in transportation of packets to BS of LEACH protocol is covered by our proposed protocol named as REER. We have overcome the effects of cluster head method creation of LEACH in our proposed protocol by using a special node outside the cluster for data aggregation. This technique is based on cluster formation and the data loss ratios of the clusters are measured so that the energy consumption can be effectively reduced. Reliable transmission can be served in the clusters using that special node. And QoS is provided.

REFERENCES

1. Mrs. Asha Ahlawat, Ms Vineeta Malik “An extended vice-cluster selection approach to improve v leach protocol in wsn” 2013 Third International Conference on Advanced Computing & Communication Technologies.
2. Chinchu T Sony, Sangeetha C P “Multi-hop LEACH Protocol with modified Cluster Head selection and TDMA schedule for Wireless Sensor Networks , Proceedings of 2015 Global Conference on Communication Technologies(GCCT 2015).
3. Ravi Kishore Kodali, Venkata Sai Kiran A., Shikha Bhandari and Lakshmi Boppana, “Energy Efficient m-level LEACH protocol”, 978-1-4799-8792-4/15/\$31.00_c 2015 IEEE.
4. Heydar Ghasemzadeh, Mehdi Rezaeian, Fatemeh Dehghan,” BN-LEACH: An Improvement on LEACH Protocol using Bayesian Networks for Energy Consumption Reduction in Wireless Sensor Networks” 2014 7th International Symposium on Telecommunications (IST’2014).
5. Shikha Magotra, Krishan Kumar “Detection of HELLO flood Attack on LEACH Protocol” 978-1-4799-2572-8/14/\$31.00_c 2014 IEEE
6. Liu, Y., Xiong, N., Zhao, Y., Vasilakos, A.V., Gao, J., Jiã, Y “Multilayer clustering routing algorithm for wireless vehicular sensor networks”, IET Commun., 2010, 4, (7), pp. 810–816.
7. Xin, G., Yong, X.W., Fang, L.: ‘An energy-efficient clustering technique for wireless sensor networks’. Proc. Int. Conf. IEEE Networking, Architecture, and Storage, June 2008, pp. 248–252.